



## DI-D200PI

2 MP Ultra Low Light Vandal Fixed Dome Camera

- 2 MP dome camera
- Strong night performance, capturing images in ultra-low light down to 0.005 lux
- Clear imaging even against strong back lighting due to 120 dB true WDR technology
- 3D DNR technology delivers clean and sharp images
- EXIR 2.0: advanced infrared technology with 30 m IR distance
- Water and dust resistant (IP66) and vandal proof (IK10)
- 4 in 1 (4 signals switchable TVI/AHD/CVI/CVBS)

## ▪ Specification

<b>Camera</b>	
Image Sensor	2.0 megapixel progressive scan CMOS
Max. Resolution	1920 (H) × 1080 (V)
Min. Illumination	0.005 Lux@(F2.0, AGC ON), 0 Lux with IR
Shutter Time	PAL: 1/25 s to 1/50,000 s;NTSC: 1/30 s to 1/50,000 s
Day & Night	IR Cut Filter
Angle Adjustment	Pan: 0° to 355°, Tilt: 0° to 75°, Rotation: 0° to 355°
Signal System	PAL/NTSC
<b>Lens</b>	
Lens Type	2.8 mm, 3.6 mm, 6 mm
Focal Length & FOV	106° (2.8 mm), 82° (3.6 mm), 51° (6 mm)
Lens Mount	M12
<b>Illuminator</b>	
Supplement Light Type	IR
Supplement Light Range	Up to 30 m
Smart Supplement Light	Yes
<b>Image</b>	
Image Parameters Switch	STD/HIGH-SAT
Image Settings	Brightness,Mirror,Sharpness,AGC
Frame Rate	PAL: 1080p@25fps NTSC: 1080p@30fps
Day/Night Mode	Auto/Color/BW (Black and White)
Wide Dynamic Range (WDR)	≥120 dB
Image Enhancement	WDR,BLC,HLC
Noise Reduction	3D DNR
<b>Interface</b>	
Video Output	Switchable TVI/AHD/CVI/CVBS,1 HD analog output
<b>General</b>	
Power	12 VDC ±25%, max. 4.6 W *You are recommended to use one power adapter to supply the power for one camera.
Material	Metal
Dimension	Φ 110.8 mm × 84.7 mm (Φ 4.4" × 3.3")
Weight	Approx. 374 g (0.82 lb.)
Operating Condition	-40 °C to 60 °C (-40 °F to 140 °F), Humidity: 90% or less (non-condensation)
Language	English
<b>Approval</b>	
Protection	IP67, IK10

## ▪ Available Model



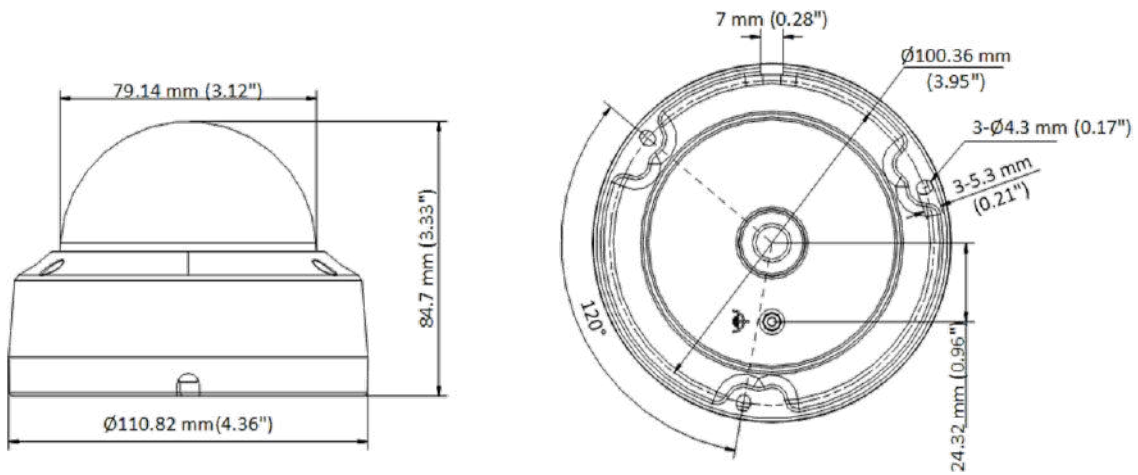

DI-D200PI

▪ **Dimension**



▪ **Accessory**

▪ **Optional**

DI-1272ZJ-110B Wall Mount	DI-1258ZJ Wall Mount	DI-1272ZJ-110 Wall Mount	DI-1271ZJ-110 Pendant Mount	DI-1275ZJ-SUS Vertical Pole Mount
				
DI-1276ZJ-SUS Corner Mount	DI-1280ZJ-DM18 Junction Box	DI-1259ZJ Inclined Ceiling Mount	DI-1250ZJ Rain Shade	DI-1253ZJ-M Rain Shade
