

VidoNet

Product Features

- Supports 1.25Gbps/1.0625Gbps bit rates
- Duplex LC connector
- Hot pluggable SFP footprint
- 850nm VCSEL laser transmitter and PIN photo-detector
- Applicable for 550m on 50/125µm, 300m on 62.5/125µm MMF connection
- Low power consumption, < 0.5W
- Digital Diagnostic Monitor Interface
- Compliant with SFP MSA and SFF-8472
- Very low EMI and excellent ESD protection
- Operating case temperature:
- Commercial :0 to 70 °C

RoHS Compliant 1.25Gbps 850nm Optical Transceiver 550m Reach



VT-GSFPM

Applications

- Gigabit Ethernet
- Fiber Channel
- Switch to Switch interface
- Switched back plane applications
- Router/Server interface
- Other optical transmission systems

The 2630, The SFP transceivers are high performance, cost effective modules supporting data-rate of 1.25Gbps and 550m transmission distance with MMF. The transceiver consists of three sections: a VCSEL laser transmitter, a PIN photodiode integrated with a trans-impedance preamplifier (TIA) and MCU control unit. All modules satisfy class I laser safety requirements. The transceivers are compatible with SFP Multi-Source Agreement (MSA) and SFF-8472. For further information, please refer to SFP MSA.

VidoNet

Absolute Maximum Ratings

Parameter	Symbol	Min.	Max.	Unit	Note
Supply Voltage	V _{cc}	-0.5	4.0	V	
Storage Temperature	T _s	-40	85	°C	
Relative Humidity	RH	0	85	%	

Note: Stress in excess of the maximum absolute ratings can cause permanent damage to the transceiver.

General Operating Characteristics

Parameter	Symbol	Min.	Typ	Max.	Unit	Note
Data Rate	DR	1.0625	1.25		Gb/s	
Supply Voltage	V _{cc}	3.13	3.3	3.47	V	
Supply Current	I _{ccs}			144	mA	
Operating Case Temp.	T _c	0		70	°C	
	T _i	-40		85		

Electrical Characteristics (T_{OP(C)} = 0 to 70 °C, V_{CC} = 3.13 to 3.47 V)

Parameter	Symbol	Min.	Typ	Max.	Unit	Note
Transmitter						
Differential data input swing	V _{IN,pp}	250		1200	mV _{pp}	1
Tx Disable Input-High	V _{IH}	2.0		V _{cc} +0.3	V	
Tx Disable Input-Low	V _{IL}	0		0.8	V	
Tx Fault Output-High	V _{OH}	2.0		V _{cc} +0.3	V	2
Tx Fault Output-Low	V _{OL}	0		0.8	V	2
Input differential impedance	R _{in}		100		Ω	
Receiver						
Differential data output swing	V _{out,pp}	250		550	mV _{pp}	3
Rx LOS Output-High	V _{ROH}	2.0		V _{cc} +0.3	V	2
Rx LOS Output-Low	V _{ROL}	0		0.8	V	2

Notes:

1. TD+/- are internally AC coupled with 100Ω differential termination inside the module.
2. Tx Fault and Rx LOS are open collector outputs, which should be pulled up with 4.7k to 10kΩ resistors on the host board. Pull up voltage between 2.0V and V_{cc}+0.3V.
3. RD+/- outputs are internally AC coupled, and should be terminated with 100Ω (differential) at the user SERDES.

VidoNet

Optical Characteristics (TOP(C)= 0 to 70 °C, VCC = 3.13 to 3.47 V)

Parameter	Symbol	Min.	Typ	Max.	Unit	Note
Transmitter						
Operating Wavelength	λ	840	850	860	nm	
Ave. output power (Enabled)	P _{AVE}	-10		-3	dBm	1
Extinction Ratio	ER	9			dB	1
RMS spectral width	$\Delta\lambda$			0.65	nm	
Rise/Fall time (20%~80%)	Tr/Tf			0.25	ps	2
Output Optical Eye	Compliant with IEEE802.3 z & ITU G.957 Compliant (class 1 aser safety)					
Receiver						
Operating Wavelength	λ	840	850	860	nm	
Receiver Sensitivity	P _{SENI}			-18	dBm	3
Overload	P _{AVE}	-3			dBm	3
LOS Assert	P _a	-35			dBm	
LOS De-assert	P _d			-20	dBm	
LOS Hysteresis	P _d -P _a	0.5			dB	

Notes:

1. Measured at 1250 Mb/s with PRBS 2²³⁻¹ NRZ test pattern.
2. Unfiltered, measured with a PRBS 2²³⁻¹ test pattern @1250Mbps
3. Measured at 1250 Mb/s with PRBS 2²³⁻¹ NRZ test pattern for BER < 1x10⁻¹⁰

Pin Defintion And Functions

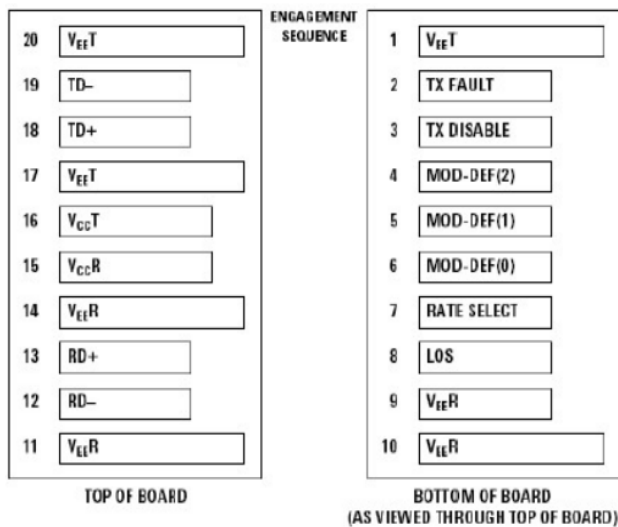

TOP VIEW OF BOARD

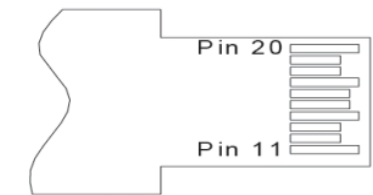

BOTTOM VIEW OF BOARD

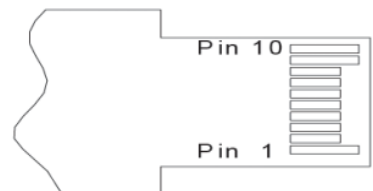

VidoNet

Digital Diagnostic Specifications

The 2630 transceivers can be used in host systems that require either internally or externally calibrated digital diagnostics.

Parameter	Symbol	Units	Min.	Max.	Accuracy	Note
Transceiver temperature	DTemp-E	°C	-45	+90	±5°C	1
Transceiver supply voltage	DVoltage	V	2.8	4.0	±3%	
Transmitter bias current	DBias	mA	2	15	±10%	2
Transmitter output power	DTx-Power	dBm	-13	0	±3dB	
Receiver average input power	DRx-Power	dBm	-21	0	±3dB	

Notes:

1. When Operating temp.=0~70 °C, the range will be min=-5, Max=+75
2. The accuracy of the Tx bias current is 10% of the actual current from the laser driver to the laser
3. Internal/ External Calibration compatible.

Typical Interface Circuit

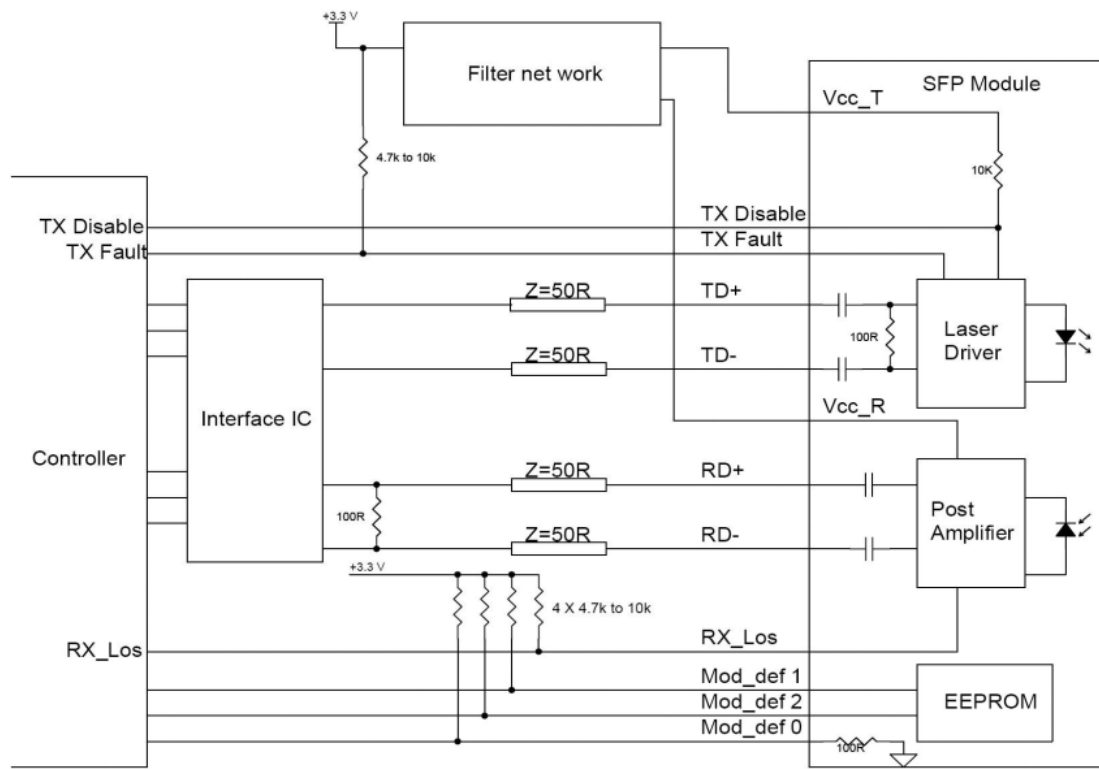

VidoNet

Package Dimensions

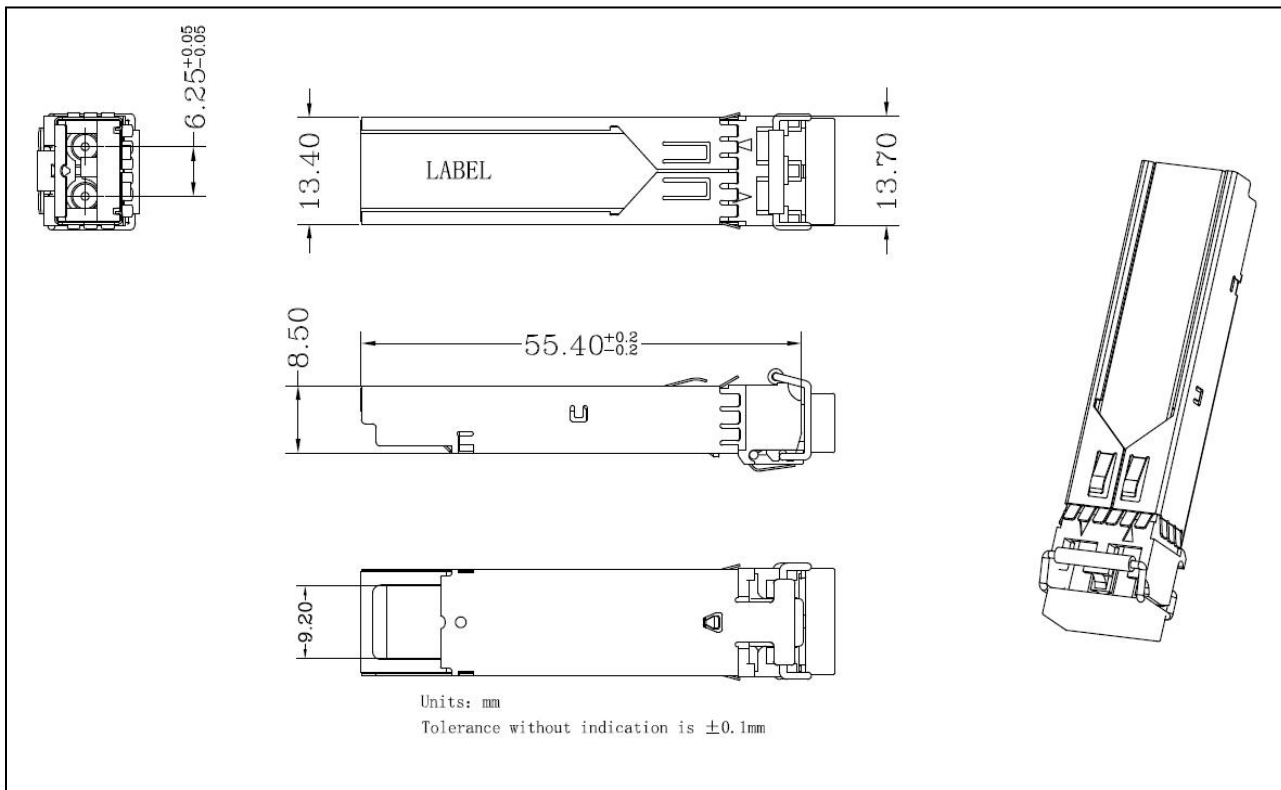

Ordering Information

Part Number	Description
2630	SFP,1.25Gbps, 850nm, Multimode,550m, 0~70°C, with DDM